

Gyro Sensor XV-3500CB

Application manual

2006/6/20
EPSON TOYOCOM Corporation
Design Dept.
Device engineering team

XV-3500CB Specifications

- Best suited detect level and sensitivity for picture stabilize.
- 2.7V to 3.3V operating voltage.
- High stability detect angler rate with using quartz crystal vibration.
- Ultra small package with detection axis perpendicular to a mounting side.
- Excel in sustainable environmental capability with hermetic sealing.
- Easily mount with no external parts.
- Easily mount with small package.
- Low power consumption.
- Good drop shock resistance.



1) Absolute maximum rating

Parameter	Symbol	Value	Unit	Note
Power supply voltage	VDD	-0.3 ~ 7.0	V	VSS=0V
Input voltage	VIN	-0.3 ~ VDD+0.3	V	VSS=0V
Storage temperature	T _{STG}	-40 ~ +85	°C	
Soldering condition		350 °C 3sec		

2) Operating range

Parameter	Symbol	Value	Unit	Note
Operating voltage	VDD	2.7 ~ 3.3	V	VSS=0V
Operating temperature	Topr	-20 ~ +80	°C	
Output current	I _{VO}	0 ~ ±100	μA	

3) Electrical characteristics

(VDD=2.7~3.3V, V_{SS}=0V, Ta=-20~+80°C)

Parameter	Symbol	Condition	Specification			Unit
			MIN	TYP	MAX	
Drive frequency	fd			A:46.5 B:50.3		kHz
Scale Factor	So			0.67		mV/dps
Scale Factor variation with temp.	Spt	Vdd=3V based on 25°C	-5		5	%
Bias	V0	Ta=25°C	Vref-0.05	Vref	Vref+0.05	V
Reference voltage	Vr		1320	1350	1380	mV
Rate range	I		-300		300	dps
Non linearly	NI	Ta=25°C			±5	%FS
Phase delay	φ ₂₀	20Hz phase delay angle		4		Degree
Band width	BW	Phase delay 90 degree		200		Hz
Crosse axis	OS	Ta=25°C			±5	%
Start up time	Tsta	Ta=25°C, VDD=3V		240		msec
Current	Operation mode	Iop		1.7		mA
Consumption	sleep mode	Isleep		1		mA
Quiescent noise	rN	Using EPSON circuit *1			20	mVp-p

*1 : EPSON Circuit shows Noise measurement circuit (P9)

External dimension and material

1) External dimension

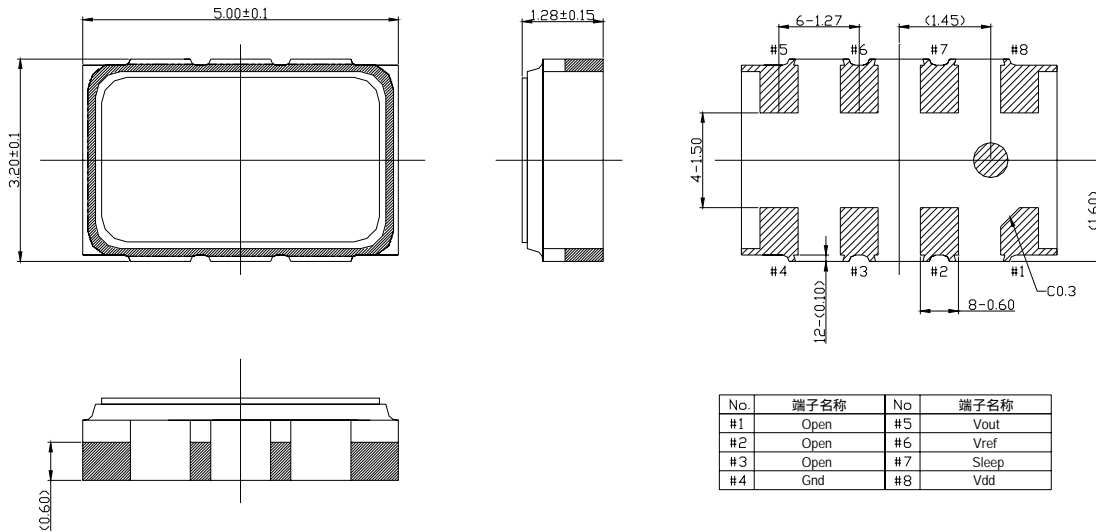

Pin No.	Pin name	I/O	Function
1	-	-	EPSON test pin. Please do not connect this pin.
2	-	-	EPSON test pin. Please do not connect this pin.
3	-	-	EPSON test pin. Please do not connect this pin.
4	Gnd	-	GND pin
5	Vout	O : Output	Output angular rate
6	VREF	O : Output	Reference output
7	SLEEP	I : Input	Sleep control input pin
8	VDD	-	Operating Voltage pin

Recommendable patterning

Following is only design example. For actual design work, please consider optimum condition together with mounting density, reliability of soldering and mountability etc. Please package it so that the solder does not adhere to the part of the seal hole.

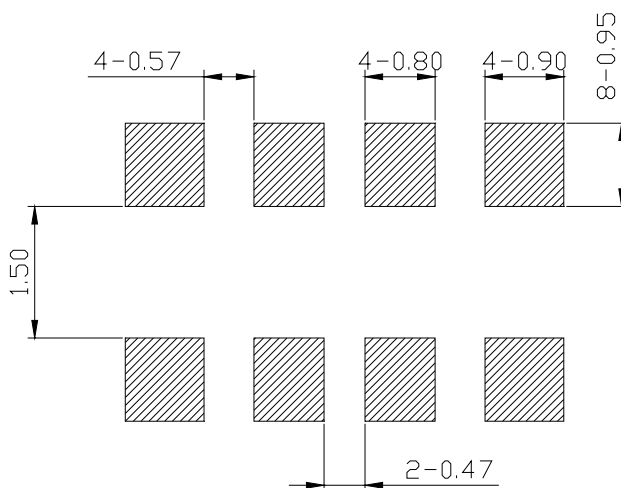

Sleep function

When a sleep control terminal is in L or an open state, it is normal operation. When a sleep control terminal is set to H, it is in a sleep state. Since only a circuit required for an oscillation is operated, consumption of current can be reduced. Moreover, while the consumption current at the time of non-operating can be stopped low, the starting time after sleep release can be shortened.

SLEEP pin

SLEEP pin	Operation
Lo or OPEN	Normal operation
High	Power save mode

Detect direction

Detect direction is shown as in the following figure. Please mount carefully to detect direction.

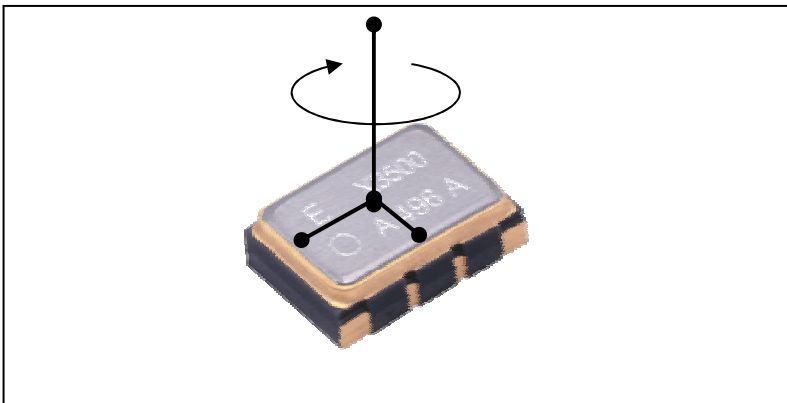

Reflow Profile

Heat testment condition of reflow oven

Preheating temperature: +170 °C Preheating time: 100 s

Heating temperature: +220 °C Heating time : 35 s

Peak temperature must not exceed +260 °C.

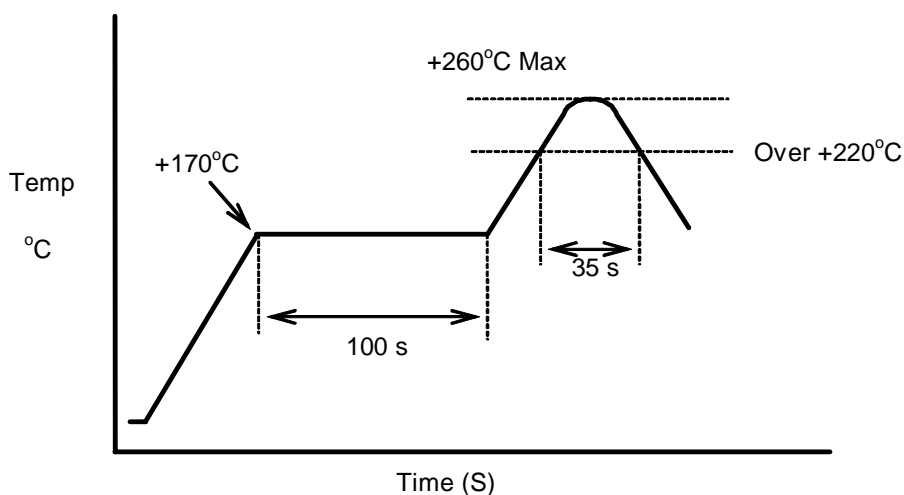

XV-3500CB DATA

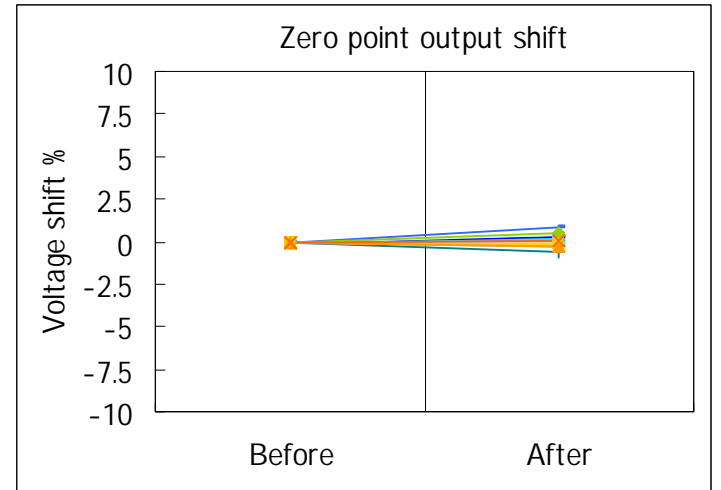
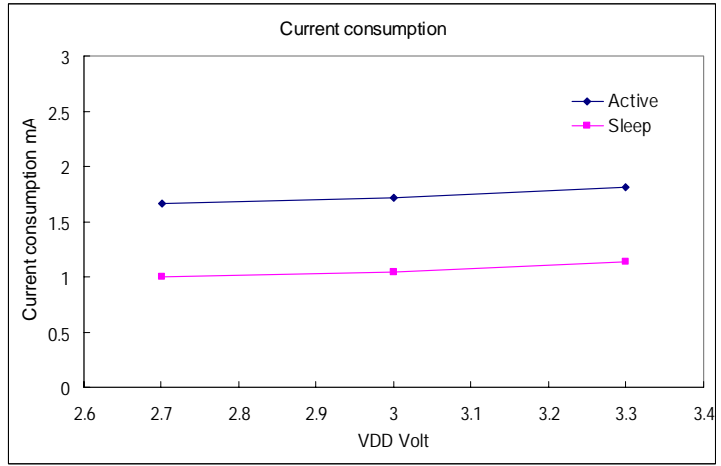
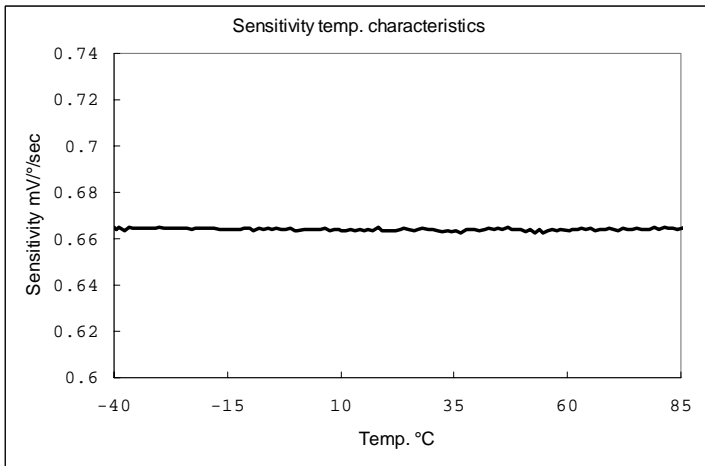
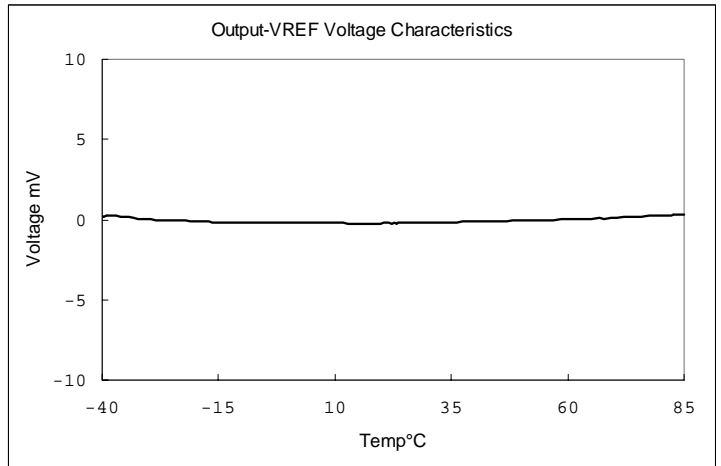
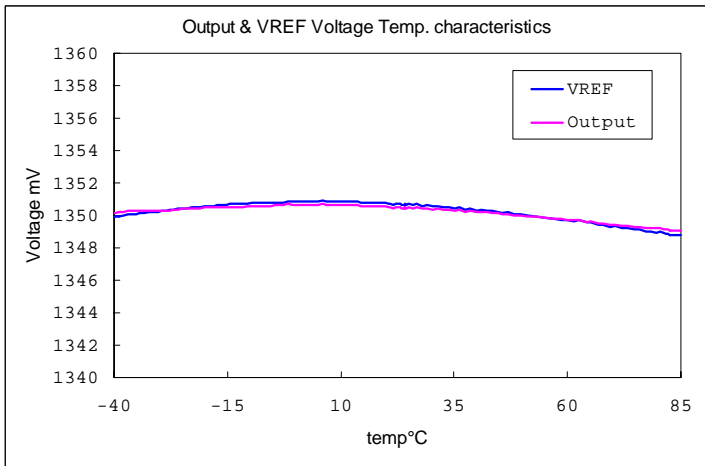

These data measure of central tendency. Please tell us if you need each tolerance and each data.

Circuit design example

1) Output circuit design With HPF Ver.1

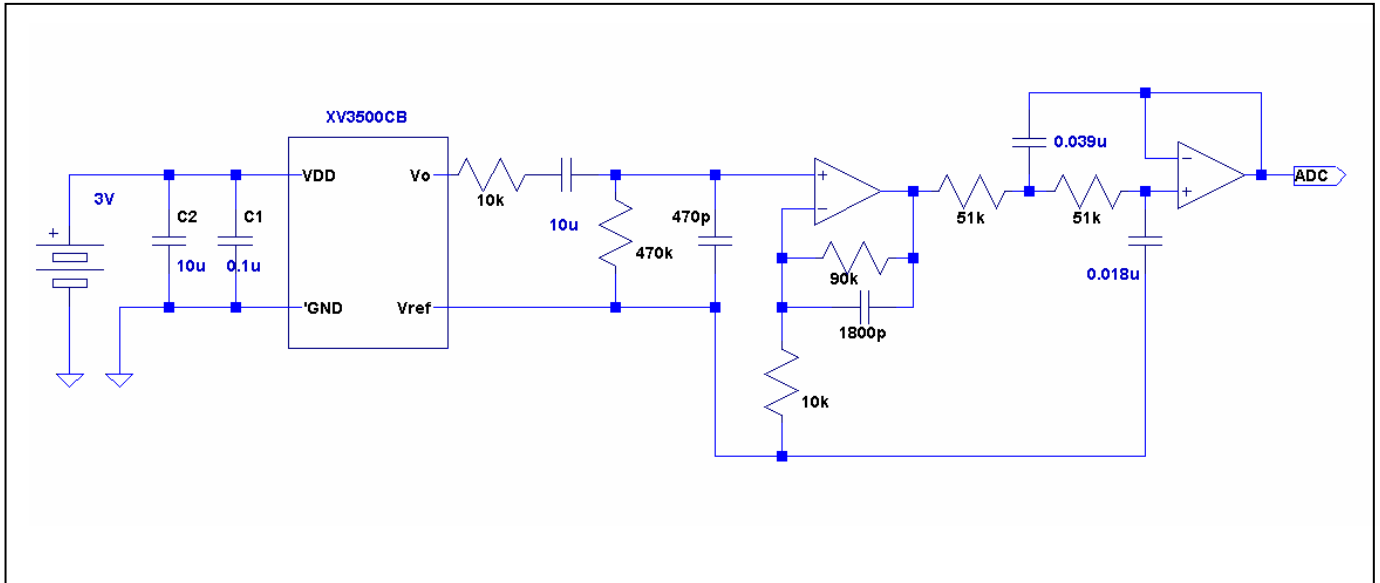

With HPF Ver.2

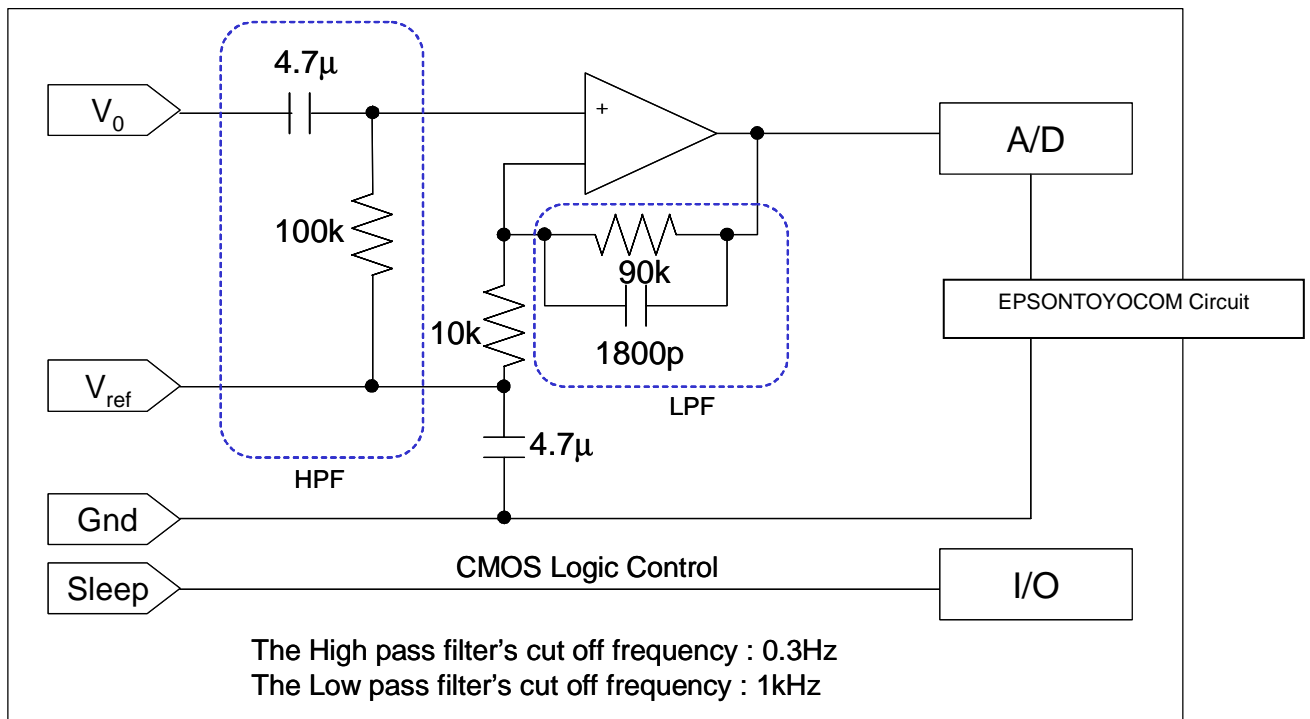

Attention

The output using these circuits does not warrant the characteristic of XV-3500CB.
Please use this circuit as an example of reference of product comparison.

Noise feature from power supply

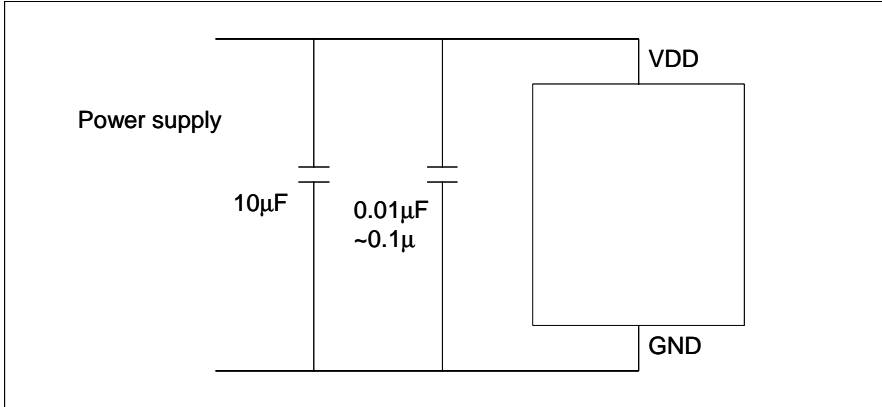

Please connect a bypass capacitor immediately near the power supply terminal. A capacitor should connect 0.01uF ~ 0.1uF and 10uF to the arrangement in a row.

Noise measurement circuit

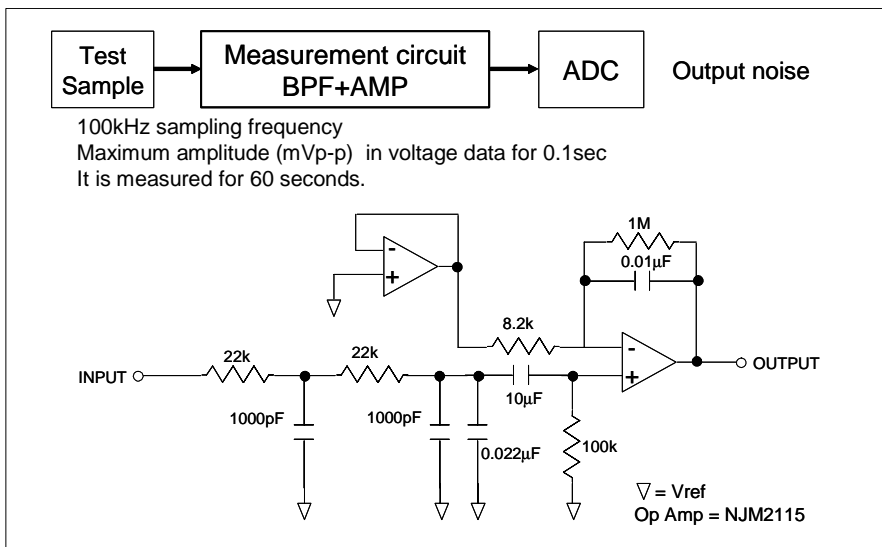

Select AD converter

XV-3500CB has resonance frequency disparity (different detection and drive resonance frequency) 800Hz +/-300Hz. When you use sampling with ADC, you need to separate a sampling frequency from resonance frequency disparity, and need to set it up. And we recommend you that it has anti areaging LPF set up.

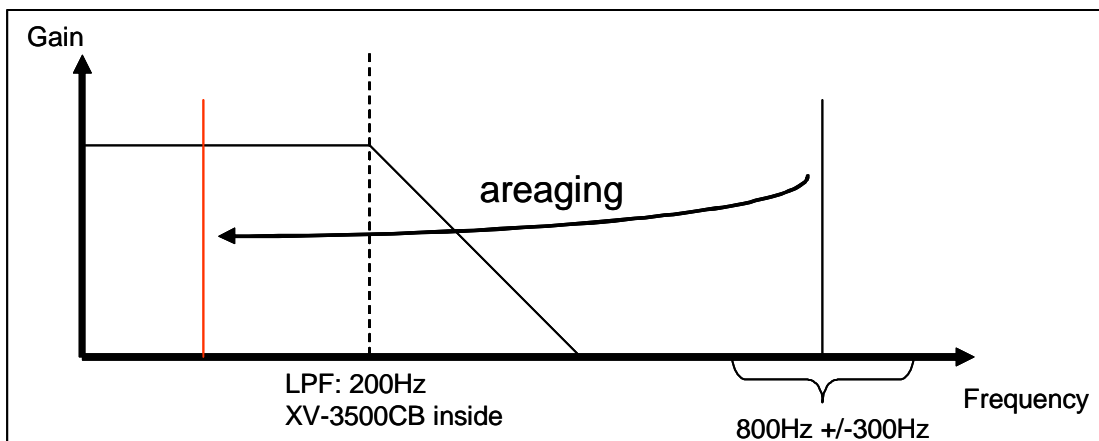

Handling precautions -EPSONTOYOCOM gyro sensor is using quartz crystal parts. Please handle and please pay attention to the next point.-

1. This crystal product is designed in consideration of shock resistance. However, it may be destroyed by the conditions of a shock. In case product is dropped, and too much shock are added, please be sure to check the characteristic.
2. If too much shock is added when a crystal product is mounted automatically, it will lead to change or degradation of the characteristic (In the case of product adsorption, chucking, and substrate mounting) Therefore, please set up the conditions that a shock is small if possible. Please be sure to test before use in your company, and check that there is no influence in the characteristic. Please confirm similarly at the time of condition change. Please be careful after mounting for a crystal product to collide neither with a machine object nor other substrates at the time of mounting.
3. This product contains the circuit that protects static electricity destruction. However, if static electricity is added superfluously, IC may break. Therefore, packing and the container to carry should use a conductive thing. Moreover, a soldering iron and a measurement circuit should use a thing without high-voltage leak, and work should take the measures against static electricity.
4. Ultrasonic washing may lead to destruction of a crystal. Our company cannot guarantee it. When used unavoidably in your company, be sure to confirm before use in your company.
5. Reflow is to 2 times. Please use soldering iron, when there is a soldering mistake. In this case, 350 degrees C or less and the conditions for less than 3 seconds are required.
6. This product has the noise of the same frequency as drive frequency. Therefore, it is necessary to remove in a suitable filter circuit.
7. Even if this sensor approaches and operates, it does not interfere in it in sound. [two or more] However, it may interfere by the common impedance of a power supply. Please be sure to check in your company.
When interference is worrisome, please use combining the sensor of different drive frequency. When using with the same board or the same power supply}
8. Another high level signal line may cause irregular output, Please take care to design output line is as short as possible, and also keeps high level signal source away from this device.
9. Please keep a gyro sensor by normal temperature and normal moisture. Refer to the packing standard document for the management method of a packing state.